

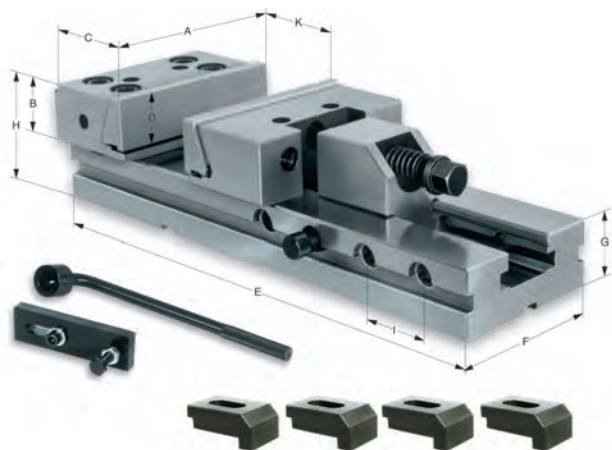

Machine vices

MSR - with draw-down jaws



APPLICATION

For universal use on milling machines and machining centers.

TYPE

Clamping system mechanical without power transmitter, manually operated.

CUSTOMER BENEFITS

- ⊕ Optimal price/performance ratio
- ⊕ Fast clamping range adjustment via bolt system

TECHNICAL FEATURES

- Scope of delivery, complete with clamping wrench, workpiece stop and four clamping claws
- With draw-down jaws
- Hardened steel body (60 HRC)
- Clamping repeatability 0.02 mm

Machine vices MSR

A11 MSR, with draw-down jaws

Item no.	Jaw width A mm	B mm	C mm	D mm	E mm	E max mm	F mm	G mm	H mm	I mm	K mm	Clamping force kN	Weight kg
161828	125	40	78	32	345	401	95	40	80	50	150	30	12,7
161827	150	50	90	40	420	487	125	50	100	50	200	50	25,6
161826	150	50	90	40	520	587	125	50	100	50	300	50	29,5
161825	175	60	97	43	655	701	145	58	118	50	400	60	51,2

A37 Clamping jaw, for movable jaw



Item no.	Contents of delivery	Size	Width mm	Height mm
006589	piece	125	125	38
006616	piece	150	150	48
006684	piece	175	171	58

A37 Clamping jaw, for fixed jaw

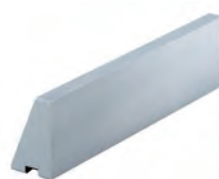

Item no.	Contents of delivery	Size	Width mm	Height mm
006590	piece	125	120	38
006617	piece	150	146	48
006687	piece	175	171	58

A37 Step jaw SB, for stationary jaw with jaw steps 5x5 mm



Item no.	Contents of delivery	Size	Width mm	Height mm
1043226 ▲	piece	125	120	38
1043228	piece	150	146	48
1043230 ▲	piece	175	171	58

A37 Step jaw SB, for movable jaw with jaw steps 5x5 mm



Item no.	Contents of delivery	Size	Width mm	Height mm
1043227	piece	125	120	38
1043229	piece	150	146	48
1043231 ▲	piece	175	171	58



Machine vices

Accessories MSR

A37

V-jaw PB with jaw steps, for movable jaw



Item no.	Contents of delivery	Size	Width mm	Height mm
1043409	piece	125	120	38
1043410	piece	150	146	48
1043411 ▲	piece	175	171	58

A37

Inclinde jaw WB, for circular parts for movable jaw

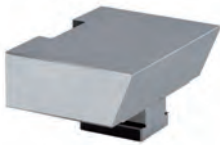

Item no.	Contents of delivery	Size	Width mm	Height mm
1043412 ▲	piece	125	120	38
1043413 ▲	piece	150	146	48
1043414 ▲	piece	175	171	58

A37

Single clamp SPE



Item no.	Contents of delivery	Size	T-slot	Thread
163329	piece	125	12	M10x45
163330	piece	125	14	M12x50
163331	piece	125	16	M12x50
163332	piece	125	18	M16x50
163333 ▲	piece	150/175	12	M10x50
163334 ▲	piece	150/175	14	M12x55
163335	piece	150/175	16	M12x55
163336	piece	150/175	18	M16x60

A37

Rotation plate DP



Item no.	Size	External Ø mm	Height
476867 ▲	125	226	23
476868 ▲	150	290	28
476870 ▲	175	320	28



RS - without power transmitter

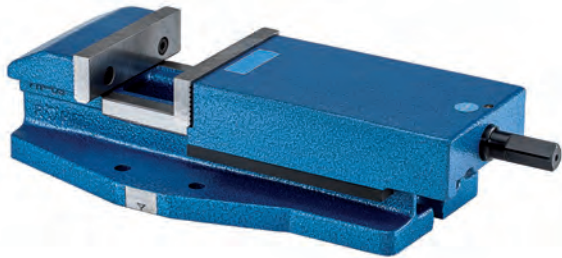

APPLICATION

For conventional machine tools.

TYPE

Clamping system mechanical without power transmitter, manually operated.

CUSTOMER BENEFITS

- ③ Optimal price/performance ratio
- ③ Entire clamping range can be bridged over by turning the handcrank
- ③ Spindle is protected from dirt and chips
- ③ Extensive assortment of jaws

TECHNICAL FEATURES

- Made of special cast iron for versatile use
- Long guidance of moving jaw
- Force transfer by means of threaded spindle
- With normal jaws SGN and handcrank
- Use on rotary plate with graduation

A11

RS, with SGN normal jaws and hand crank

Item no.	128031	128032	128033	128034	111648
Size	1	2	3	4	5
Jaw width A mm	92	113	135	160	200
B mm	85	105	125	145	185
C mm	31,6	31,6	39,6	49,6	62,6
D mm	362	423	510	575	675
F mm	260	300	365	410	460
G mm	48	58	64	70	82
H mm	50	55	70	80	90
J mm	174	200	242	273	322
K mm	160	160	200	240	280
O mm	115	125	155	175	200
P mm	60	60	70	80	118
Q mm	13	13	13	17	21
R mm	14	14	14	18	22
S mm	120	120	146	184,5	210
Y mm	12	12	16	16	20
a mm	63	63	80	100	125
b mm	13,6	13,6	15,6	19,6	24,6
c	M6	M6	M8	M8	M10
Clamping force kN	18	25	35	45	55
Weight kg	12	13,5	25	40	65

RS - without power transmitter



RS machine vice

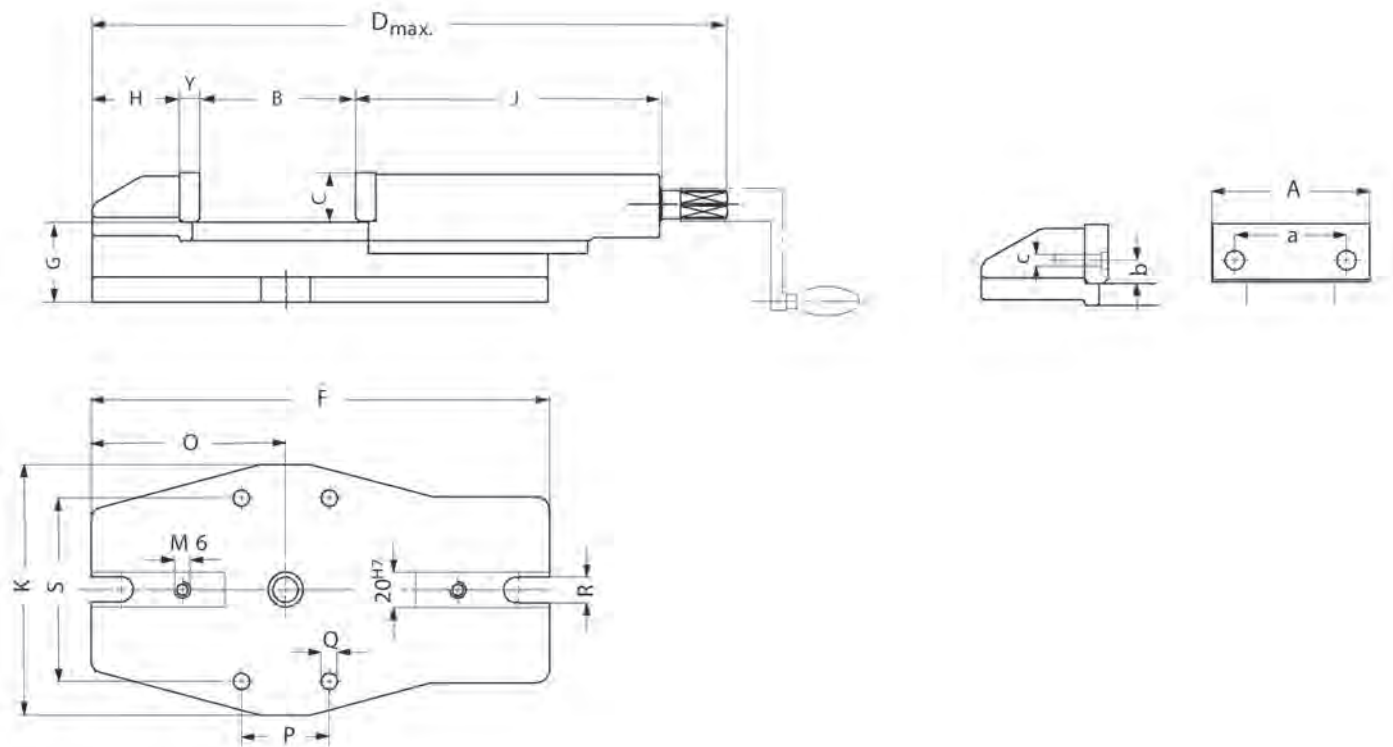

Accessories RS

A37
Draw-down jaws SNF, with spring plate, hardened and ground



Item no.	Contents of delivery	Size	Width mm	Height mm
077104 ▲	set	2	113	31,6
077105 ▲	set	3	135	39,6
077106 ▲	set	4	160	49,6
077107 ▲	set	5	200	62,6

Including fixing screws

A37
Normal jaw SGN, one side smooth, one side grooved, both sides ground

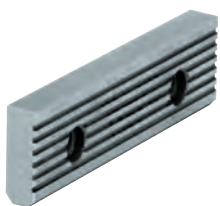

Item no.	Contents of delivery	Size	Width mm	Height mm
152752	piece	1	92	31,6
152753	piece	2	113	31,6
152754	piece	3	135	39,6
152755	piece	4	160	49,6
152759	piece	5	200	62,6

A37
Normal jaw finely checkered SGNf, reversible, to increase the specific contact pressure (higher holding forces), one side finely checkered, one side longitudinally grooved



Item no.	Contents of delivery	Size	Width mm	Height mm
163218 ▲	piece	1	92	31,6
156195	piece	2	113	31,6
156196	piece	3	135	39,6
156197	piece	4	160	49,6
156198	piece	5	200	62,6

Including fixing screws

A37
V-jaw SPR, with vertically and horizontally ground-in prisms, hardened, for combination with SGN

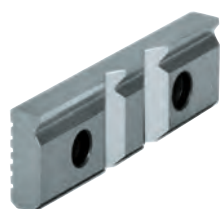

Item no.	Contents of delivery	Size	Width mm	Height mm	Chucking capacity mm	
					Horizontal	Vertical
128770	piece	1	92	31,6	3-13	5-32
082362	piece	2	113	31,6	3-13	5-32
082363	piece	3	135	39,6	4-20	6-40
082364	piece	4	160	49,6	5-29	7-48
082365	piece	5	200	62,6	6-37	8-56

Including fixing screws

A37
Normal jaw SGNA, with movable workpiece stop, hardened and ground



Item no.	Contents of delivery	Size	Width mm	Height mm
150739 ▲	piece	2	113	31,6
150740 ▲	piece	3	135	39,6
150741 ▲	piece	4	160	49,6

Including fixing screws



Machine vices

Accessories RS

C15

Hand crank HKU, with octagon socket



Item no.	Contents of delivery	Size	Octagon	Key-width SW	L
009150	piece	1	12	Octagon	80
009152	piece	2	14	Octagon	125
009153	piece	3	17		160
009154	piece	4/5	19	Octagon	200

A37

Standard rotation plate DP, with fixing screws and T-slot nuts, ground contact edge, graduation



Item no.	Size	External Ø mm	Height	Center Ø	Weight
129814	1/2	242	30	28	7,5
082442	3	280	30	28	11
082443	4	340	34	28	18

A37

Universal rotation plate DP, with fixing screws and T-slot nuts, ground contact edge, graduation



Item no.	Size	External Ø mm	Height	Center Ø	Weight
090854 ▲	5	420	40	28	23



Machine vices

UZ - central, without power transmitter



APPLICATION

For conventional machine tools.

TYPE

Clamping system mechanical without power transmitter, manually operated.

CUSTOMER BENEFITS

- ⊕ Optimal price/performance ratio
- ⊕ Spindle covered in the work area
- ⊕ Extensive assortment of jaws
- ⊕ Low design
- ⊕ The lateral jaw guides allow the vice to be easily and exactly aligned

TECHNICAL FEATURES

- Made of special cast iron for versatile use
- Use on rotary plate with graduation
- With normal jaws SGN and handcrank
- Centric clamping through the left-hand and right-hand thread of the spindle

A11
UZ, self-centering vice

UZ machine vice

Item no.	014523	014740	014752	014802 ▲	014807 ▲
Size	2	3	4	5	6
Jaw width A mm	113	135	160	200	250
B mm	110	140	180	300	400
C mm	31,6	39,6	49,6	62,6	62,6
D mm	358	408	495	655	767
F mm	344	394	480	640	751
G mm	61	65,5	74	79	85
J mm	81	87	107	123	123
K mm	132	152	180	200	220
O mm	149	174	214	294	344
P mm	50	60	60	70	80
Q mm	11	11	17	17	17
R mm	13	13	17	17	21
S mm	101	118,5	142	158	175
Y mm	12	16	16	20	20
a mm	63	80	100	125	160
b mm	13,6	15,6	19,6	24,6	24,6
c	M6	M8	M8	M10	M10
Clamping force kN	15	22	24	25	28
Weight kg	12,4	19	31	52	71

UZ - central, without power transmitter



UZ machine vice

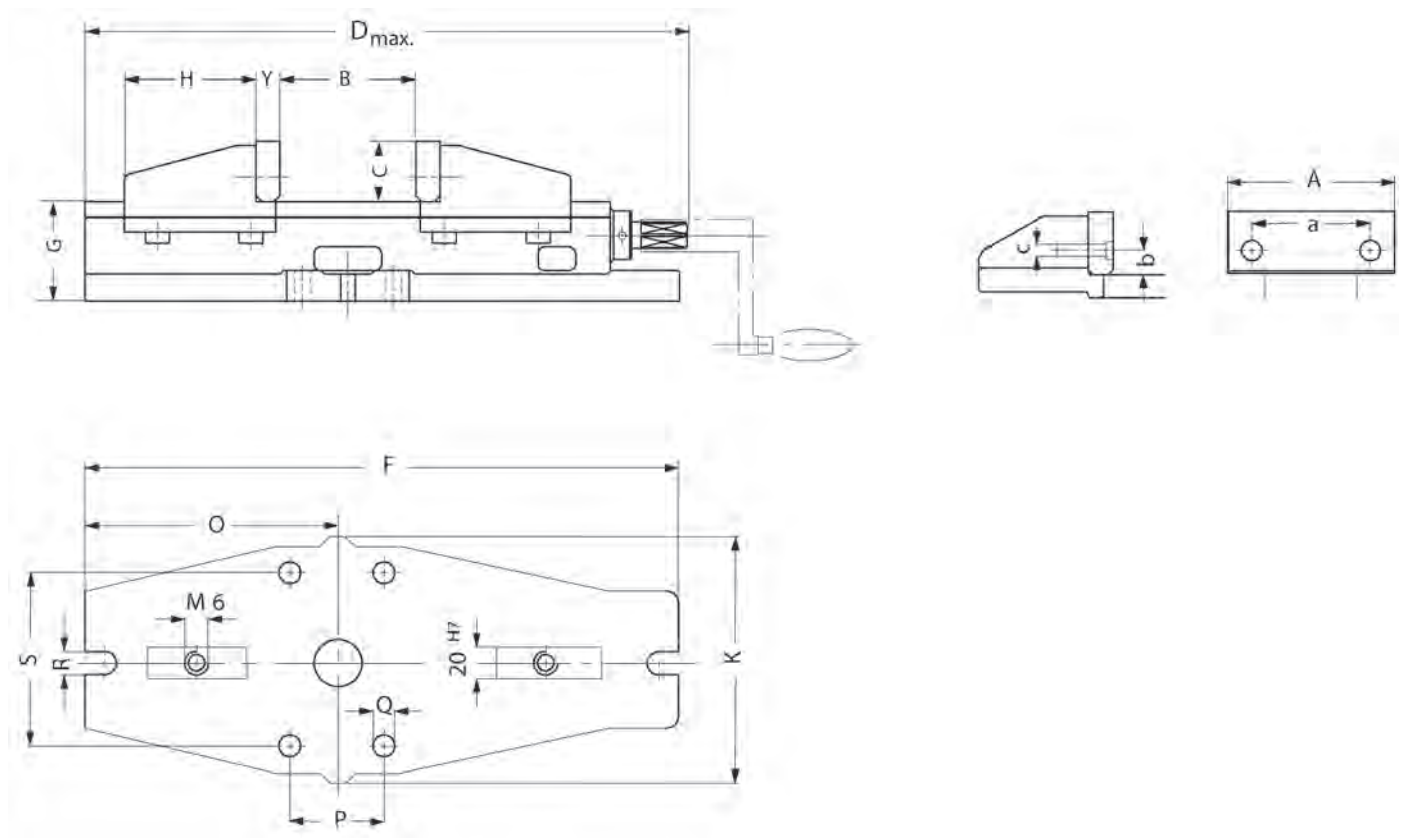



Machine vices

Accessories UZ

A37

Draw-down jaws SNF, with spring plate, hardened and ground



Item no.	Contents of delivery	Size	Width mm	Height mm
077103	set	2	90	24,6
077104 ▲	set	2	113	31,6
077105 ▲	set	3	135	39,6
077106 ▲	set	4	160	49,6
077107 ▲	set	5	200	62,6

Including fixing screws

A37

Normal jaw SGN, one side smooth, one side grooved, both sides ground



Item no.	Contents of delivery	Size	Width mm	Height mm
152767	piece	2	90	24,6
152753	piece	2	113	31,6
152754	piece	3	135	39,6
152755	piece	4	160	49,6
152759	piece	5	200	62,6
152760 ▲	piece	6	250	62,6
152762 ▲	piece		300	79,6

Including fixing screws

A37

Normal jaw finely checkered SGNf, reversible, to increase the specific contact pressure (higher holding forces), one side finely checkered, one side longitudinally grooved



Item no.	Contents of delivery	Size	Width mm	Height mm
156195	piece	2	113	31,6
156196	piece	3	135	39,6
156197	piece	4	160	49,6
156198	piece	5	200	62,6

Including fixing screws

A37

V-jaw SPR, with vertically and horizontally ground-in prisms, hardened, for combination with SGN

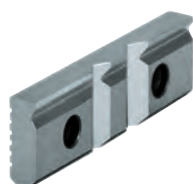

Item no.	Contents of delivery	Size	Width mm	Height mm	Chuck capacity mm	
					Horizontal	Vertical
082361	piece	2	90	24,6	3-13	5-32
082362	piece	2	113	31,6	3-13	5-32
082363	piece	3	135	39,6	4-20	6-40
082364	piece	4	160	49,6	5-29	7-48
082365	piece	5	200	62,6	6-37	8-56
082366 ▲	piece	6	250	62,6	7-45	9-65

Including fixing screws

A37

V-jaw and standard jaw SBO, unhardened and burnished, with workpiece support



Item no.	Contents of delivery	Size	Width mm	Height mm	Chuck capacity mm	
					Horizontal	Vertical
317259	set	2	110	31,8	3-12	5-32
317260	set	3	135	39,8	3-13	6-40
317261	set	4	160	49,8	5-22	7-48

Including fixing screws

Accessories UZ

A37
Normal jaw SGNA, with movable workpiece stop, hardened and ground



Item no.	Contents of delivery	Size	Width mm	Height mm
150739▲	piece	2	113	31,6
150740▲	piece	3	135	39,6
150741▲	piece	4	160	49,6

Including fixing screws

C15
Hand crank HKU, with octagon socket



Item no.	Contents of delivery	Size	Octagon	Key-width SW	L
009152	piece	2/3	14	Octagon	125
009153	piece	4	17	Octagon	160
009154	piece	5/6	19	Octagon	200

A37
Universal rotation plate DP, with T-slot screws and nuts ground contact edge, graduation



Item no.	Size	External Ø mm	Height	Center Ø	Weight
014709▲	2	245	25	28	5
014712▲	3	295	27	38	8
014715▲	4	345	30	38	11,5
014718▲	5	450	30	38	16,5
014721▲	6	450	30	38	17,3

UZ machine vice

General accessories

A37
Work locator WSA, universally adjustable, for fastening to the machine table (size 14 T-slot) or for screwing onto the NC-compact vice / machine vice (M12)



Item no.	Contents of delivery
320401	piece

A37
Fixed slot nuts NTS, hardened and ground, with fixing screw



Item no.	Contents of delivery	Size	Length mm
014823	set	20x12	22
014825	set	20x14	25
014827	set	20x16	25
014829	set	20x18	25
014831	set	20x20	22
014833	set	20x22	32